

5-6. SCHEMATIC DIAGRAM (PM-41 (-11/-21/-31/-41/-51/-61) BOARD (1/15))

PM-41 (-11/-21/-31/-41/-51/-61) BOARD (1/15)

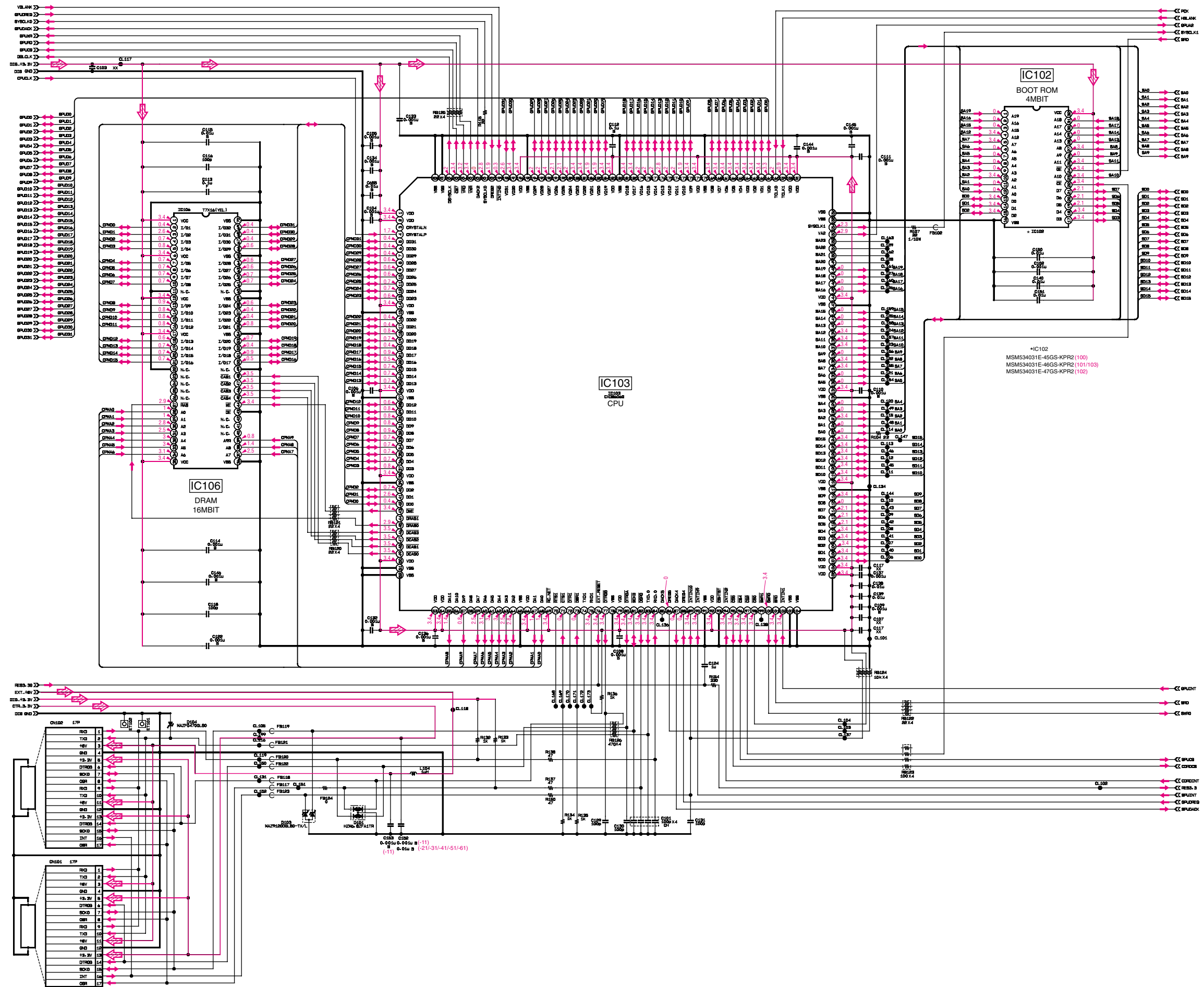

5-7. SCHEMATIC DIAGRAM (PM-41 (-71) BOARD (2/15))

PM-41 (-71) BOARD (2/15)

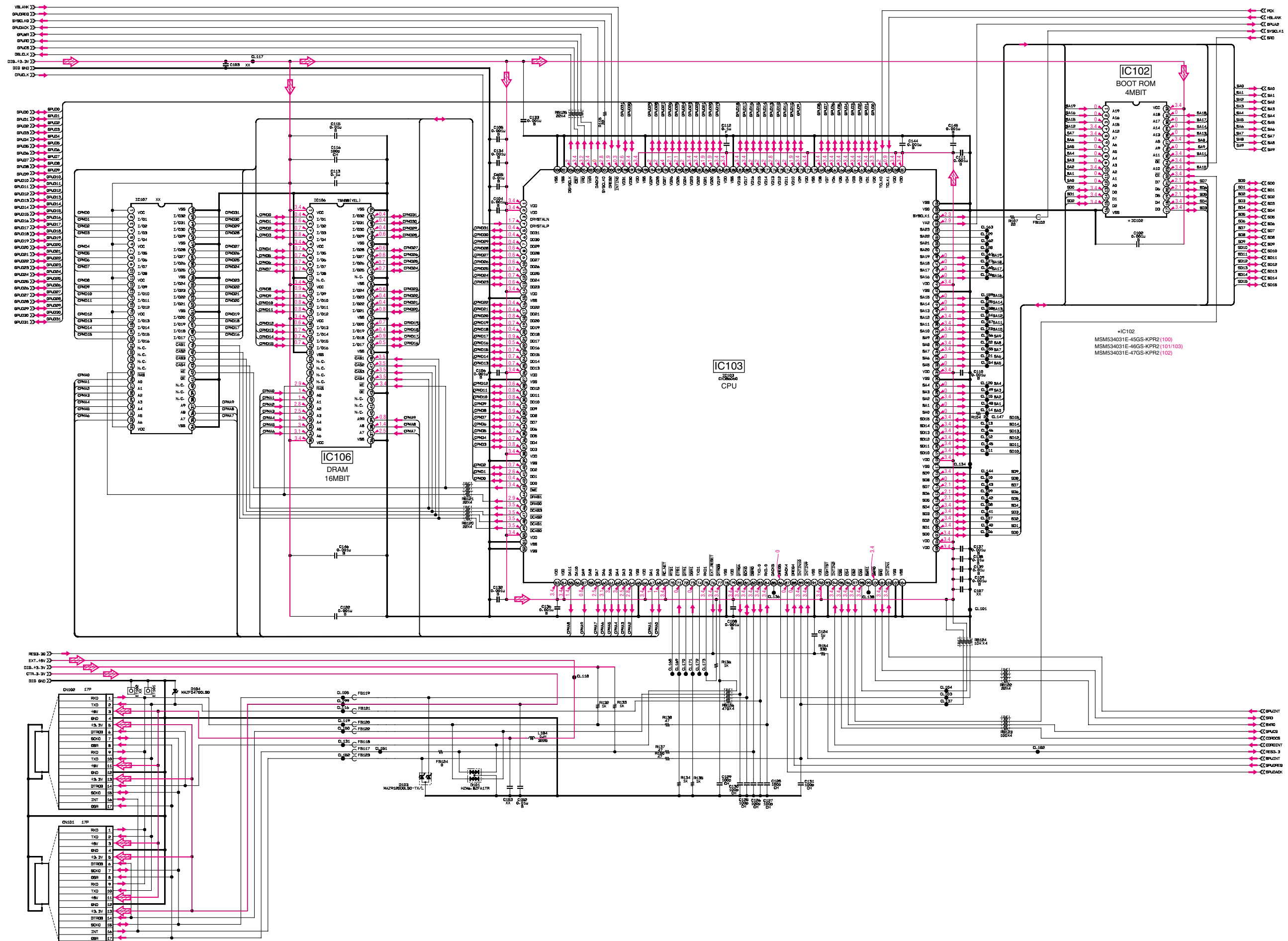

5-8. SCHEMATIC DIAGRAM (PM-41 (-11/-21/-31) BOARD (3/15))

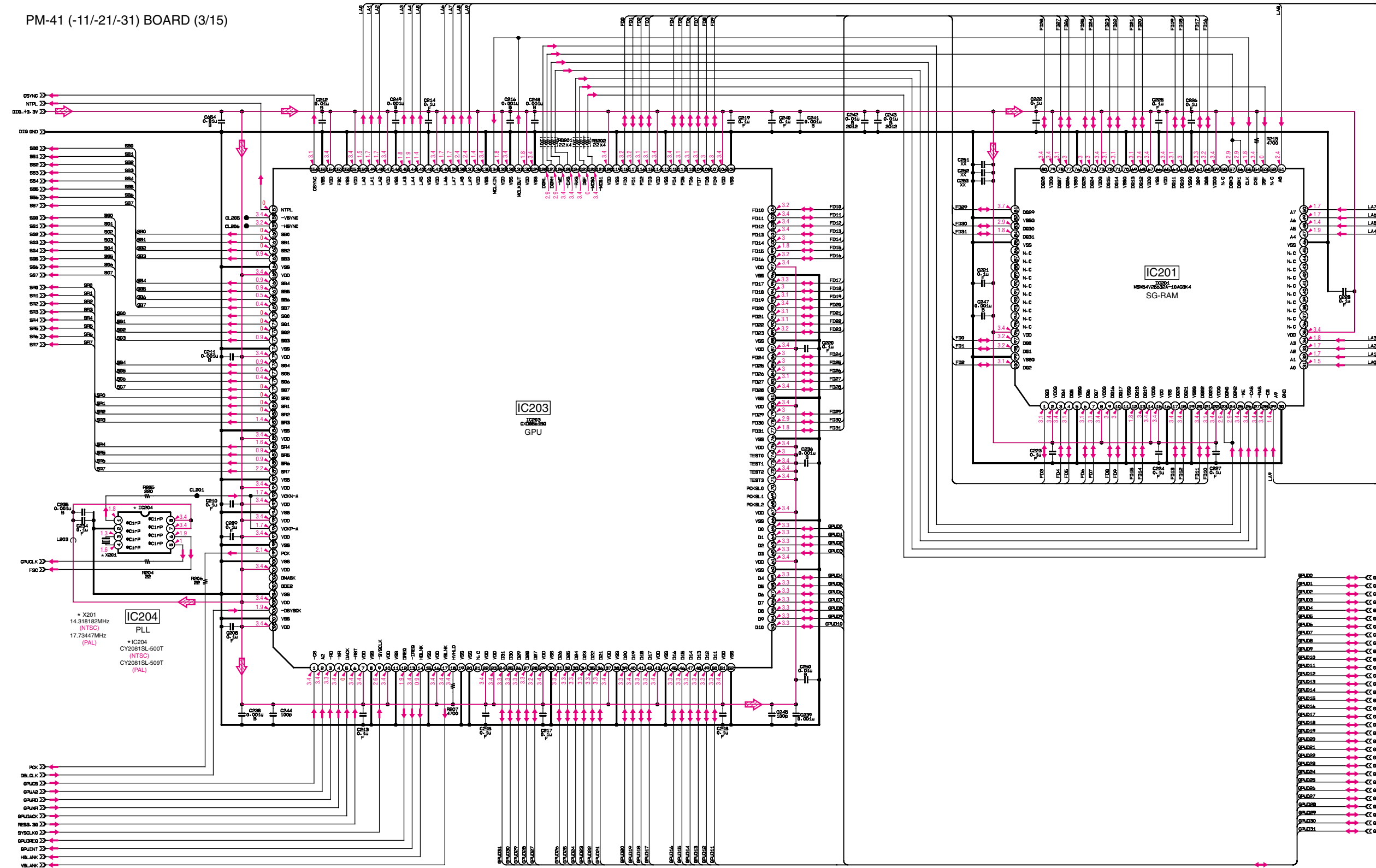

5-9. SCHEMATIC DIAGRAM (PM-41 (-41/-51) BOARD (4/15))

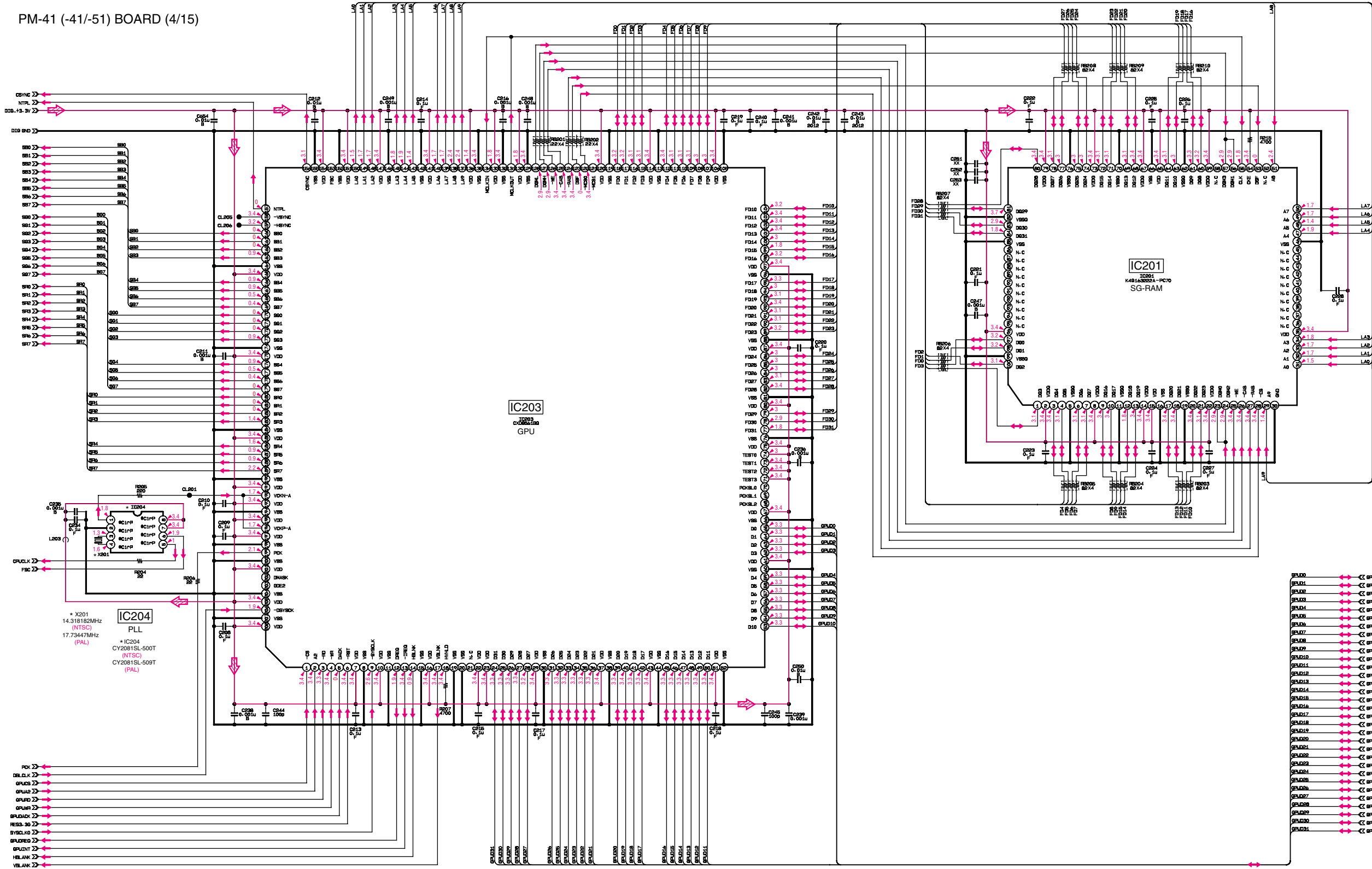

5-10. SCHEMATIC DIAGRAM (PM-41 (-61) BOARD (5/15))

PM-41 (-61) BOARD (5/15)

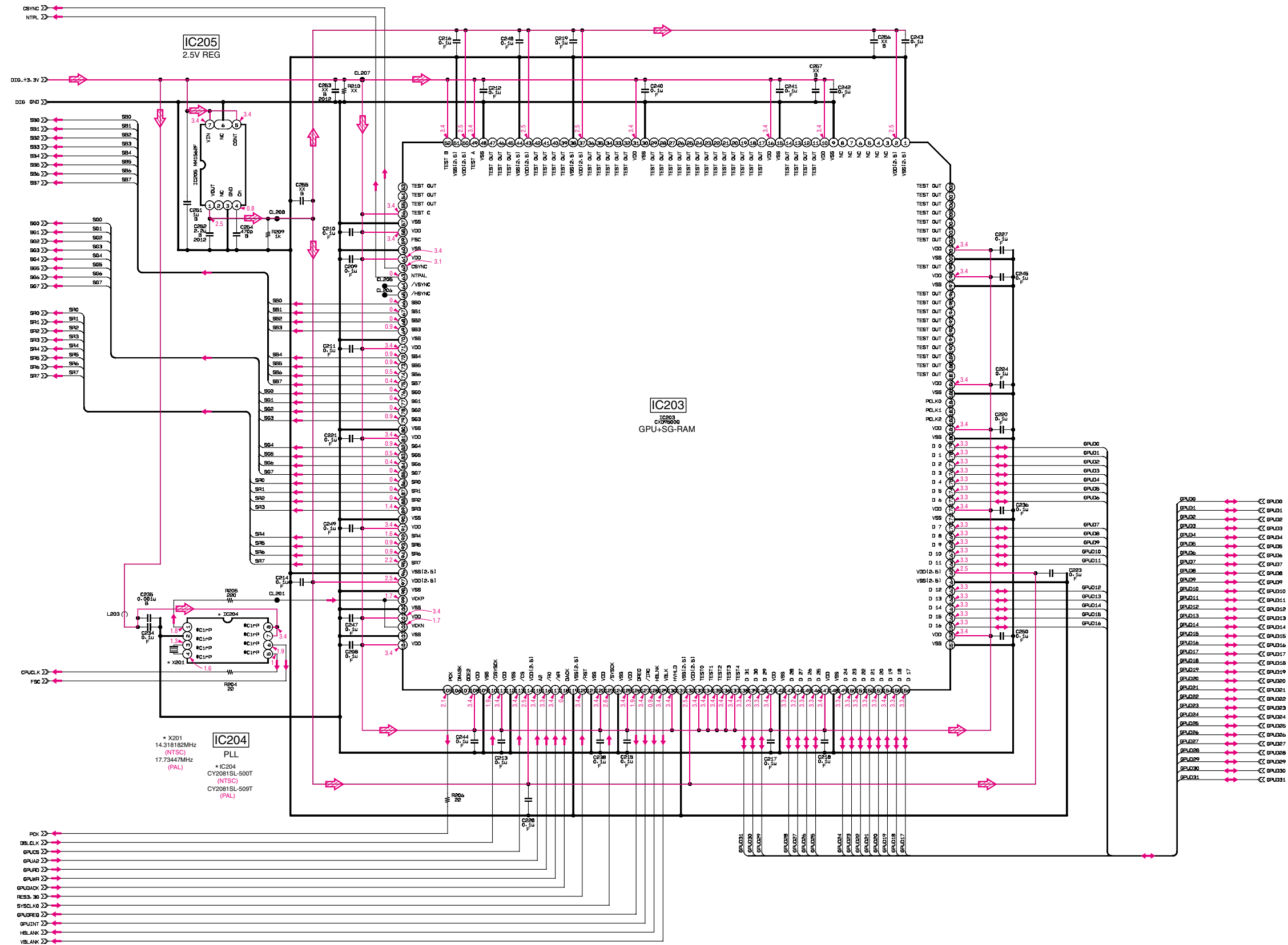

5-11. SCHEMATIC DIAGRAM (PM-41 (-71) BOARD (6/15))

PM-41 (-71) BOARD (6/15)

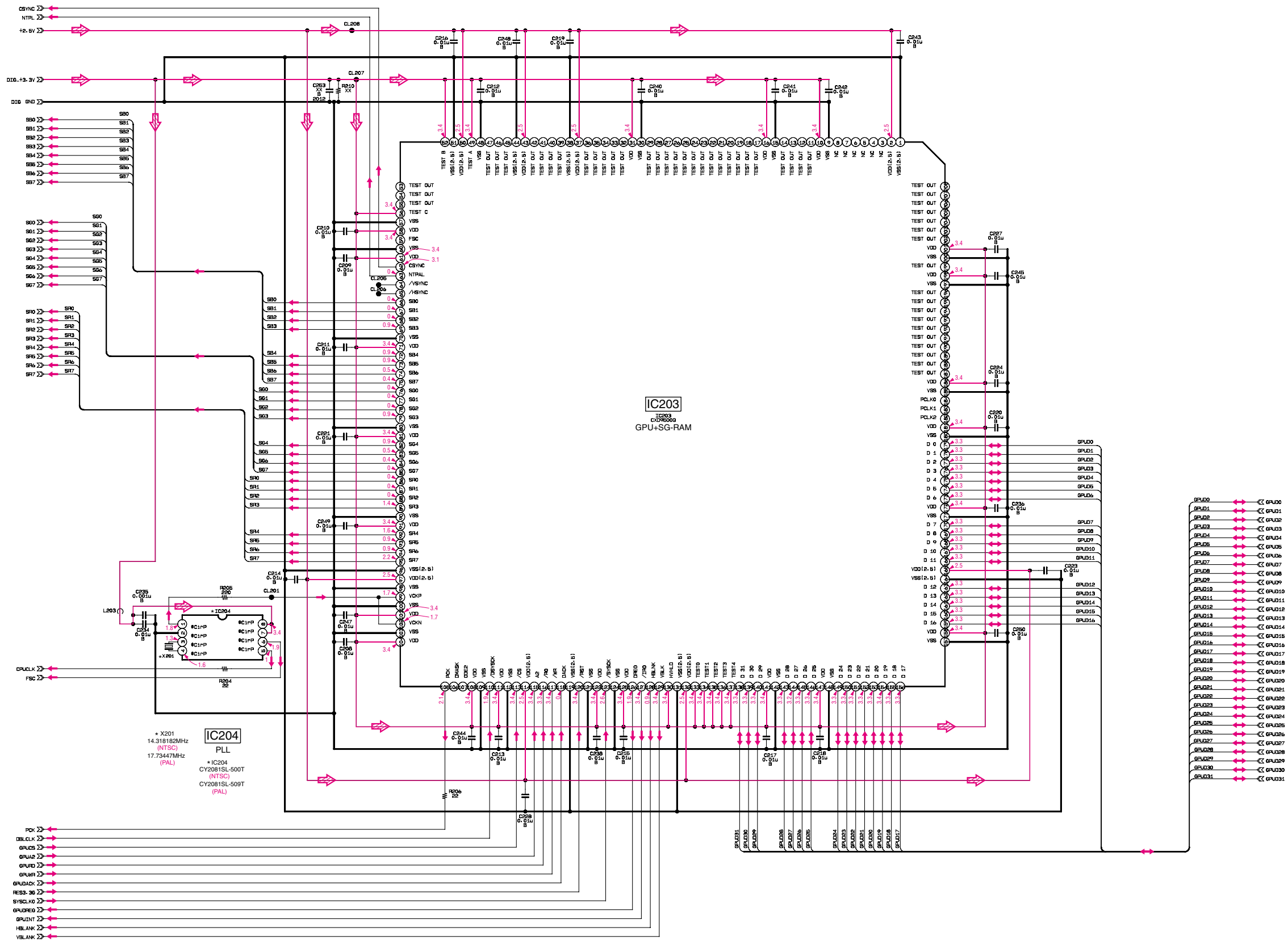

5-12. SCHEMATIC DIAGRAM (PM-41 (-11/-21/-31/-41/-51/-61) BOARD (7/15))

PM-41 (-11/-21/-31/-41/-51/-61) BOARD (7/15)

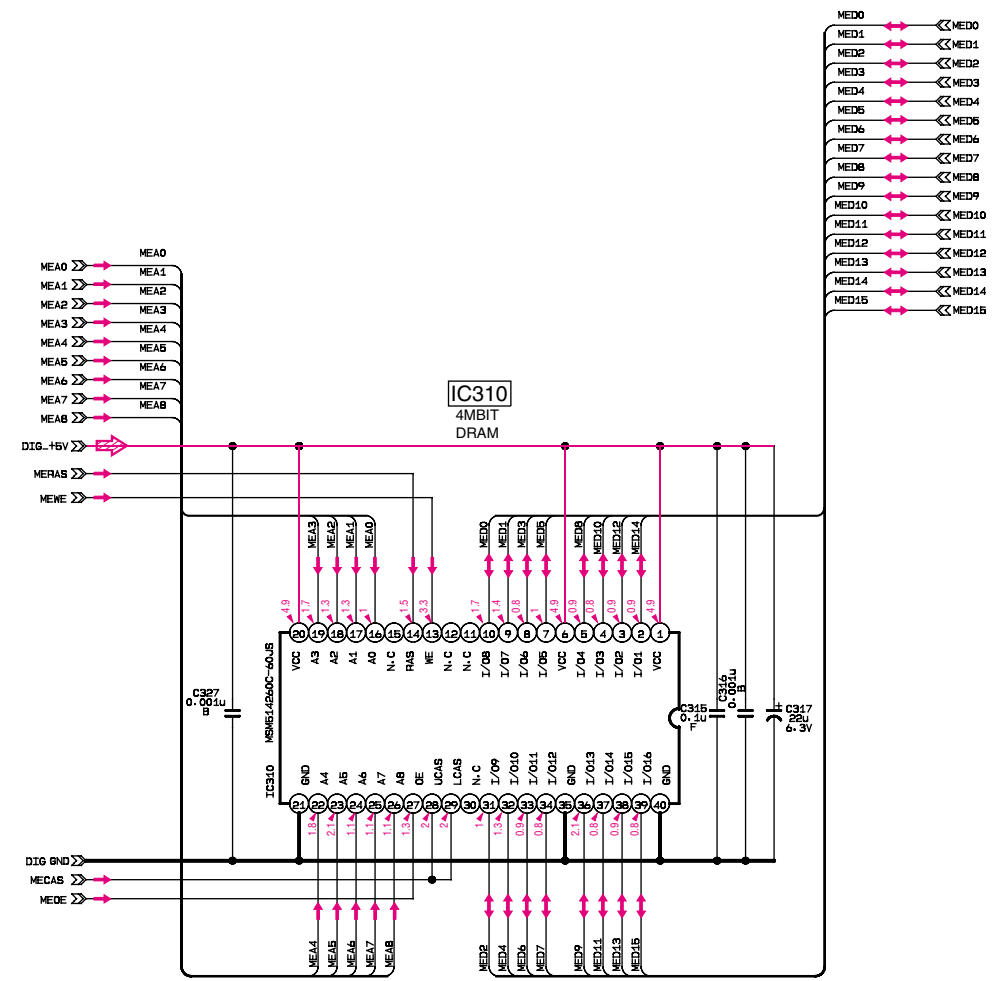
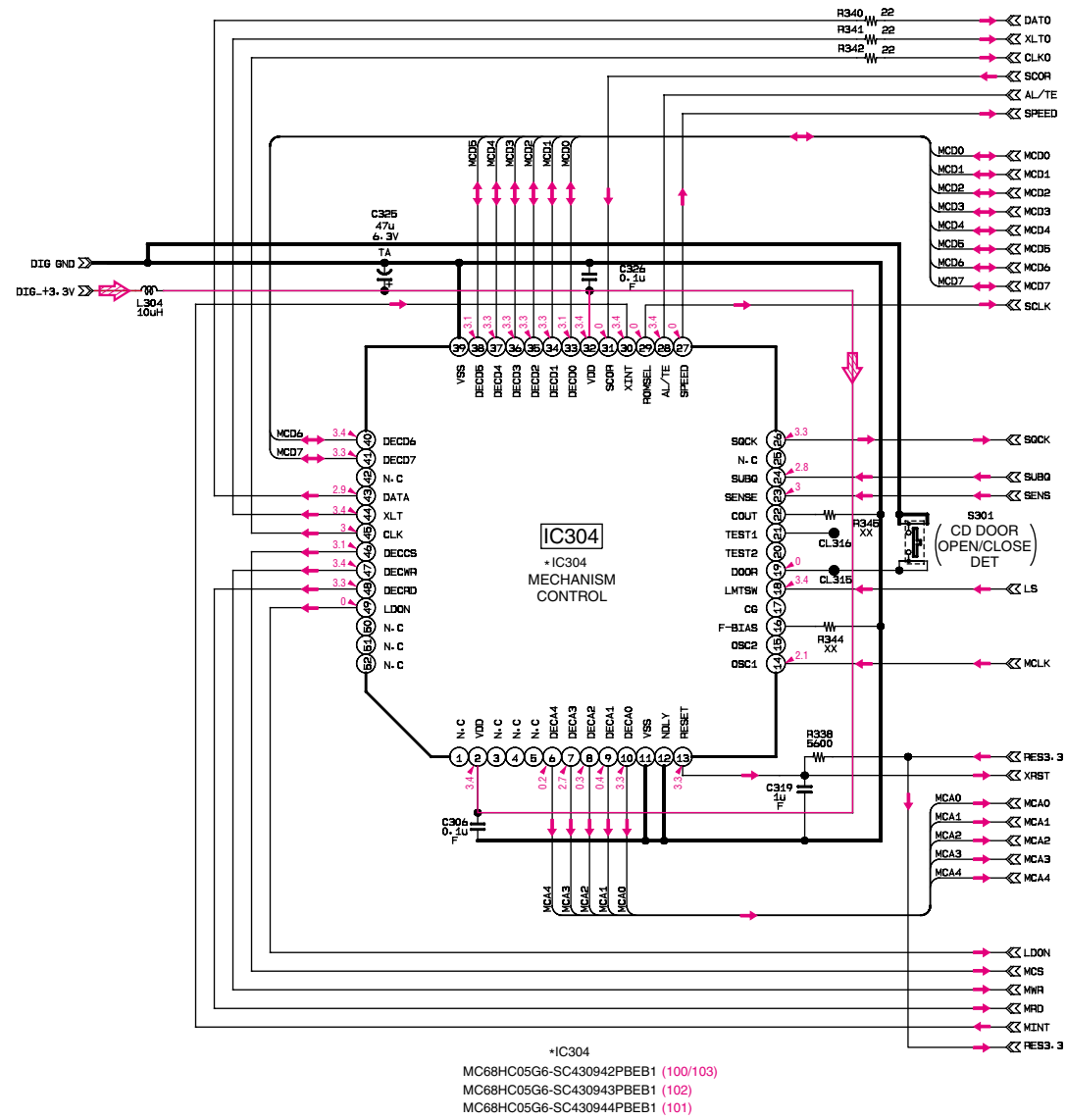

5-13. SCHEMATIC DIAGRAM (PM-41 (-71) BOARD (8/15))

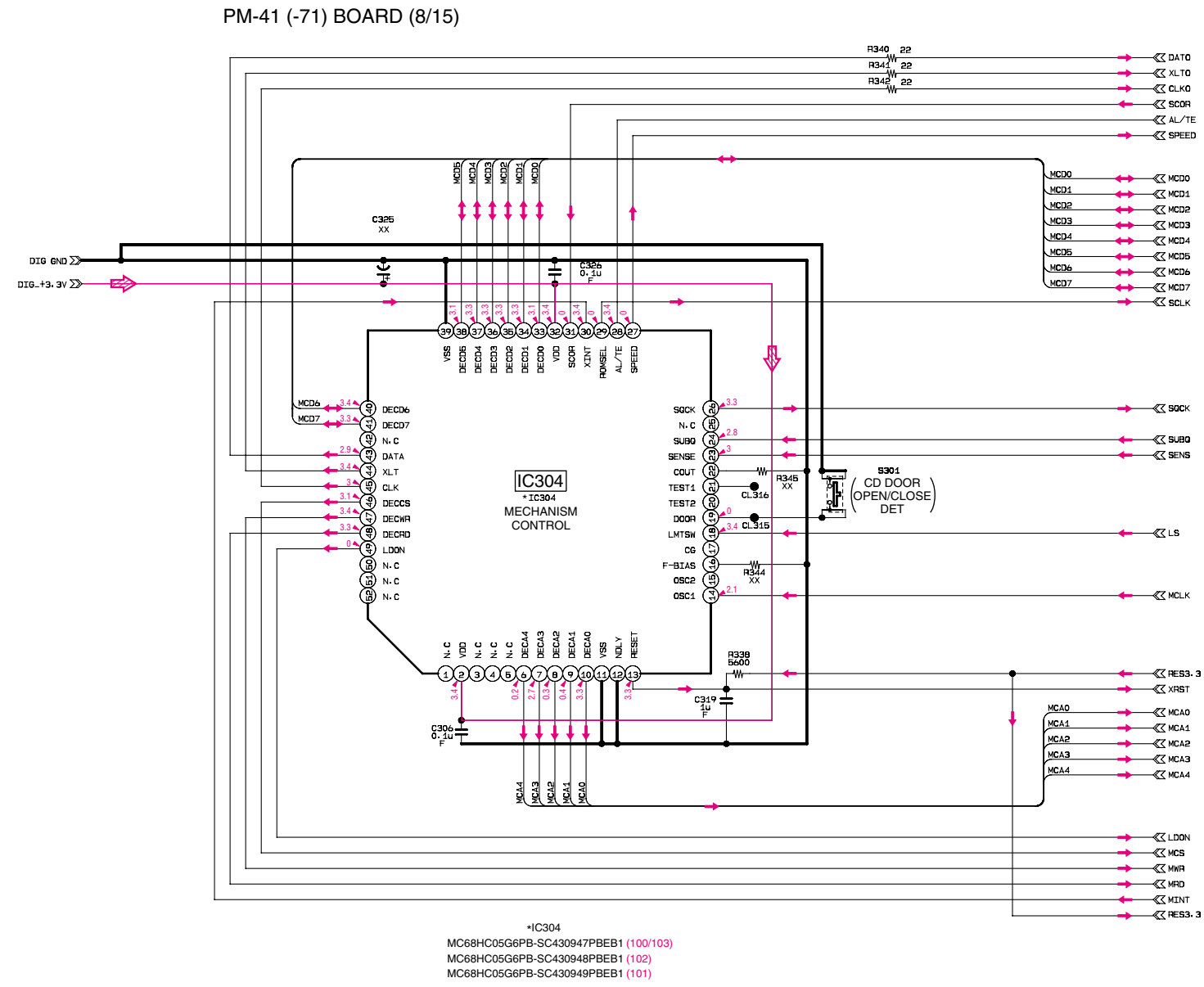

5-14. SCHEMATIC DIAGRAM (PM-41 (-11/-21/-31/-41/-51/-61) BOARD (9/15))

PM-41 (-11/-21/-31/-41/-51/-61) BOARD (9/15)

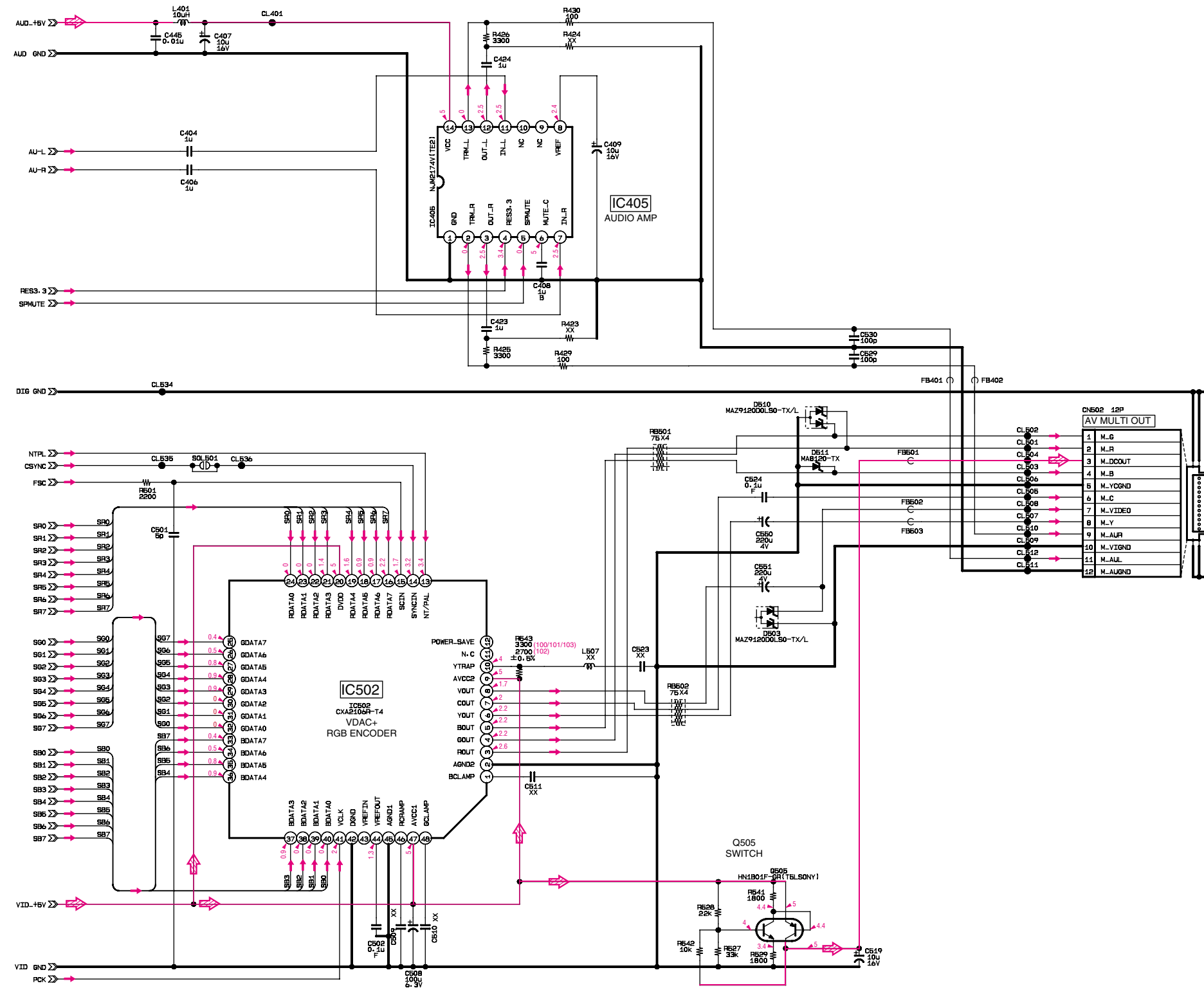

5-15. SCHEMATIC DIAGRAM (PM-41 (-71) BOARD (10/15))

PM-41 (-71) BOARD (10/15)

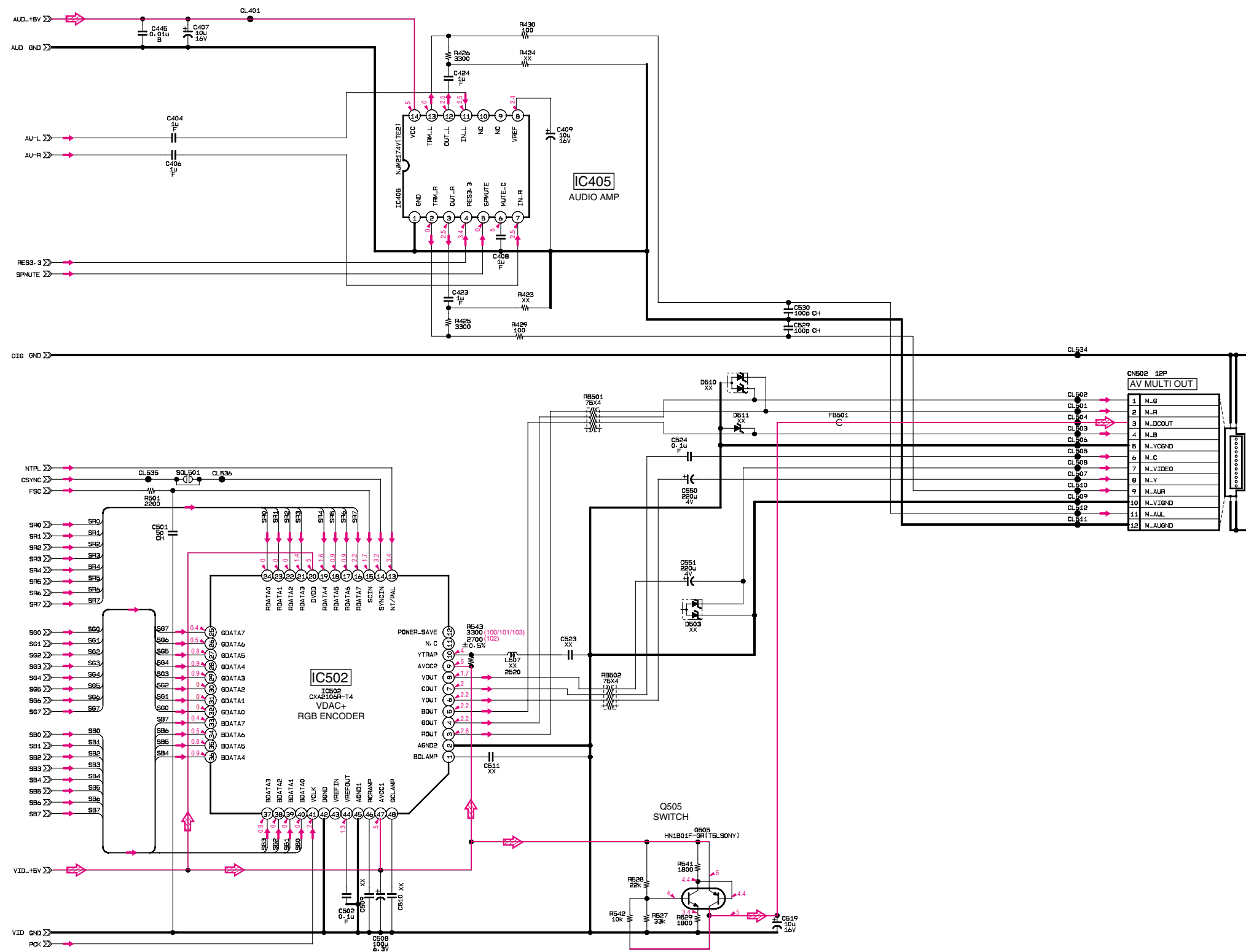

5-16. SCHEMATIC DIAGRAM (PM-41 (-11) BOARD (11/15))

PM-41 (-11) BOARD (11/15)

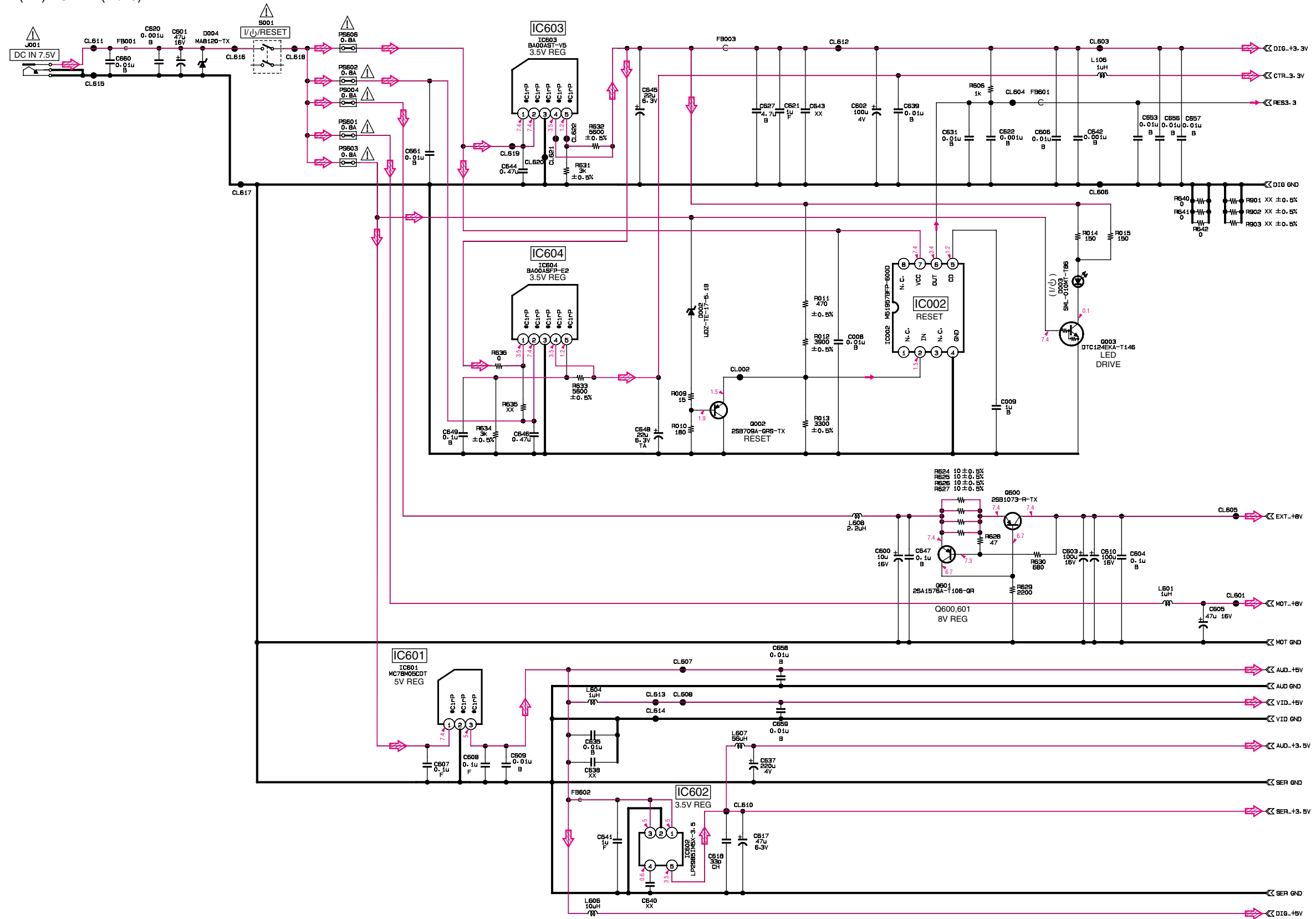

5-17. SCHEMATIC DIAGRAM (PM-41 (-21/-31/-41/-51/-61) BOARD (12/15))

PM-41 (-21/-31/-41/-51/-61) BOARD (12/15)

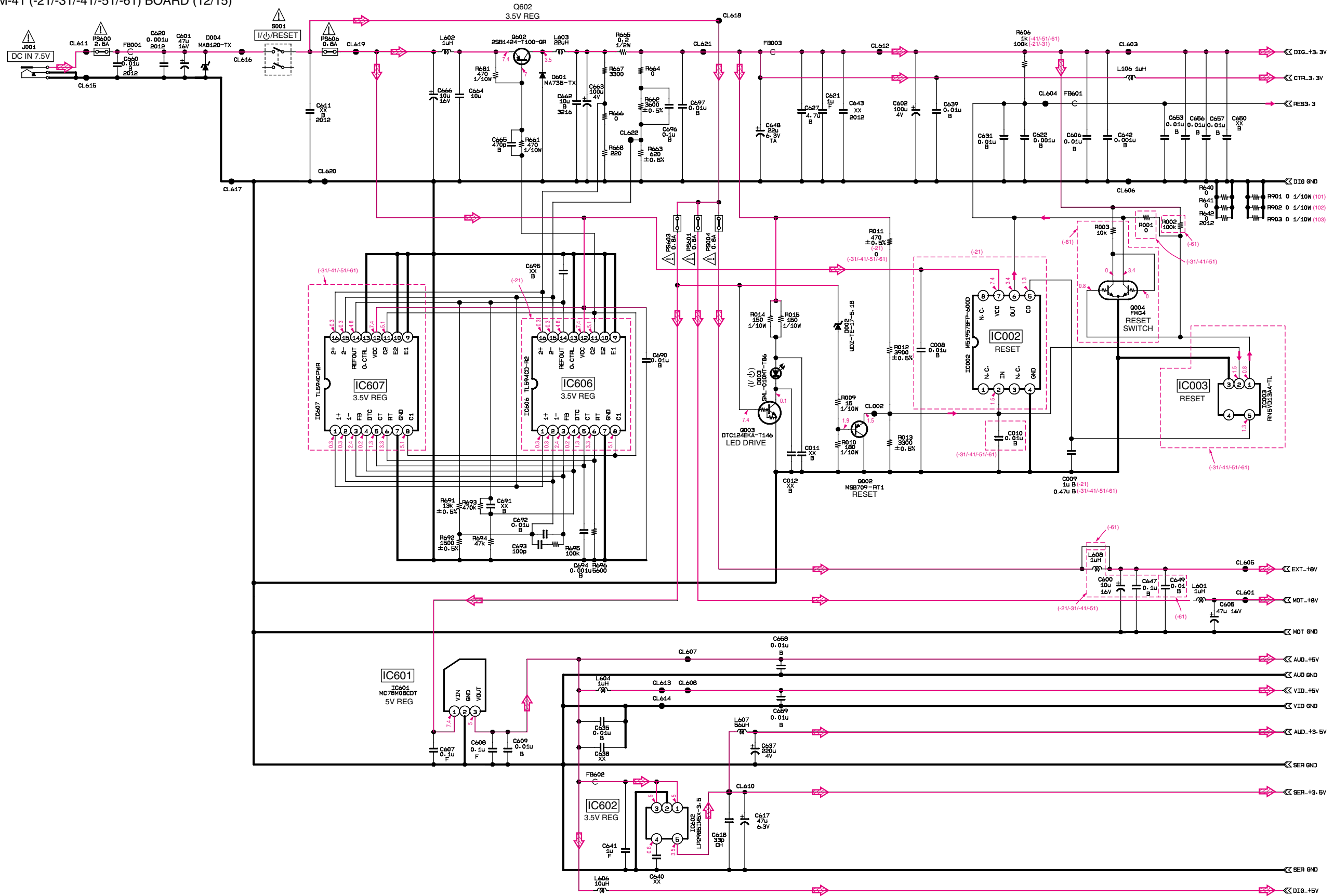

5-18. SCHEMATIC DIAGRAM (PM-41 (-71) BOARD (13/15))

PM-41 (-71) BOARD (13/15)

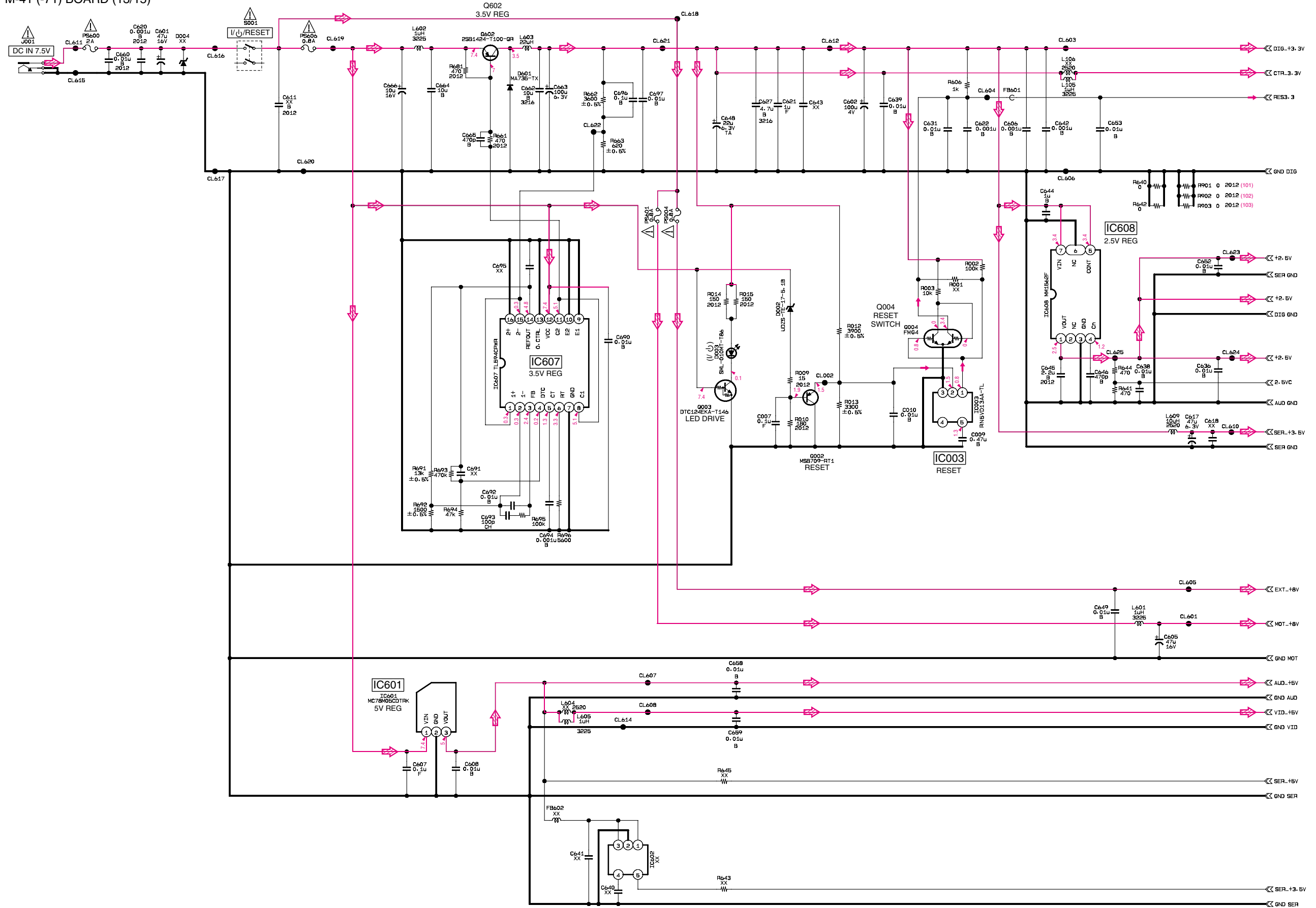

5-19. SCHEMATIC DIAGRAM (PM-41 (-11/-21/-31/-41/-51/-61) BOARD (14/15))

PM-41 (-11/-21/-31/-41/-51/-61) BOARD (14/15)

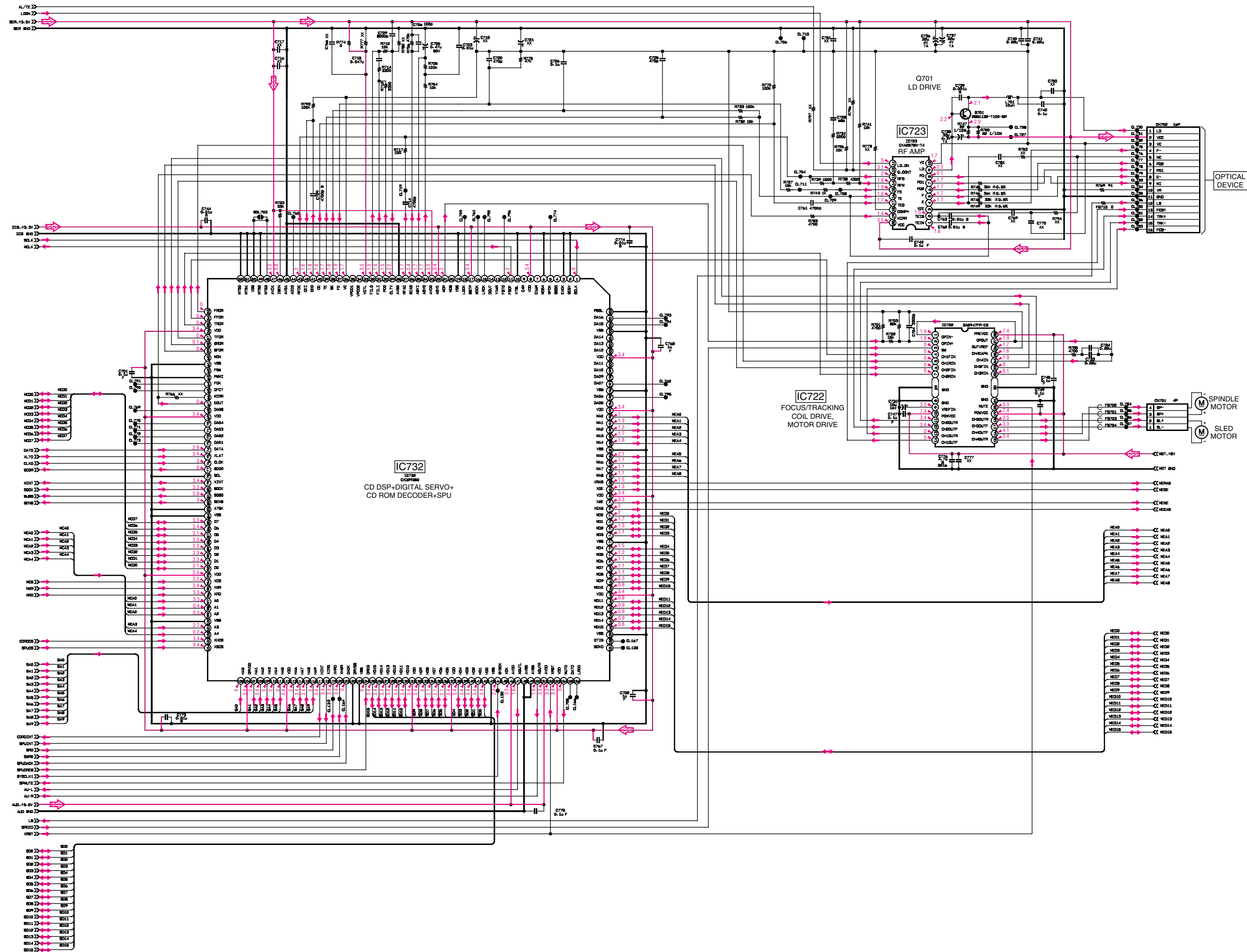

5-20. SCHEMATIC DIAGRAM (PM-41 (-71) BOARD (15/15))

PM-41 (-71) BOARD (15/15)

